

Specifications

MODELS	GS™-1530		GS™-1930	
MEASUREMENTS	US	Metric	US	Metric
Working height maximum*	21 ft	6.57 m	25 ft	7.79 m
A Platform height maximum	15 ft	4.57 m	19 ft	5.79 m
B Platform length - outside	5 ft 4 in	1.63 m	5 ft 4 in	1.63 m
extended	8 ft 4 in	2.54 m	8 ft 4 in	2.54 m
Slide-out platform extension deck	3 ft	.91 m	3 ft	.91 m
C Platform width - outside	2 ft 5 in	.74 m	2 ft 5 in	.74 m
Guardrail height: ANSI, CSA, AUS	3 ft 3 in	.99 m	3 ft 3 in	.99 m
CE	3 ft 7 in	1.10 m	3 ft 7 in	1.10 m
Toeboard height	6 in	.15 m	6 in	.15 m
D Height - stowed: fixed rails	6 ft 5 in	1.96 m	6 ft 7 in	2.00 m
folding guardrails	6 ft 8 in	2.03 m	6 ft 11 in	2.11 m
rails folded	5 ft 8 in	1.73 m	5 ft 9 in	1.75 m
E Length - stowed	6 ft	1.83 m	6 ft	1.83 m
Length - stowed extended	9 ft	2.74 m	9 ft	2.74 m
F Width	2 ft 6 in	.76 m	2 ft 6 in	.76 m
G Wheelbase	4 ft 4 in	1.32 m	4 ft 4 in	1.32 m
H Ground clearance - center	2.4 in	.06 m	2.4 in	.06 m
I - with pothole guards deployed	.75 in	.02 m	.75 in	.02 m

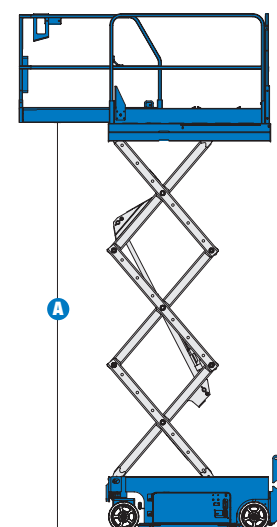
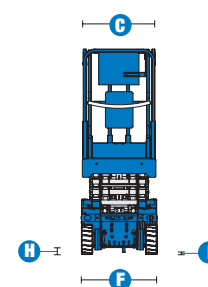
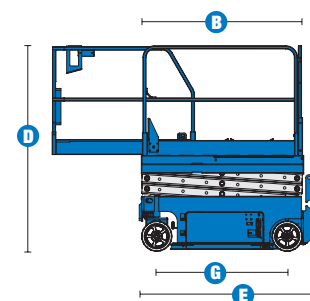

PRODUCTIVITY

Lift capacity	600 lbs	272 kg	500 lbs	227 kg
Lift capacity - extension deck	250 lbs	113 kg	250 lbs	113 kg
Drive speed - stowed	2.5 mph	4.0 km/h	2.5 mph	4.0 km/h
Drive speed - raised	0.5 mph	0.8 km/h	0.5 mph	0.8 km/h
Gradeability - stowed**	30%		30%	
Turning radius - inside	zero	zero	zero	zero
Turning radius - outside	5 ft 1 in	1.55 m	5 ft 1 in	1.55 m
Raise / lower speed	16 / 29 sec	16 / 29 sec	16 / 25 sec	16 / 25 sec
Controls	proportional		proportional	
Drive	dual front wheel		dual front wheel	
Multiple disc brakes	dual rear wheel		dual rear wheel	
Tires - solid non-marking	12 x 4.5 x 8 in	30 x 11 x 20 cm	12 x 4.5 x 8 in	30 x 11 x 20 cm

POWER

Power source	24 V DC (four 6 V 225 Ah batteries)	24 V DC (four 6 V 225 Ah batteries)
Hydraulic system capacity	3.75 gal 14.2 L	3.75 gal 14.2 L

WEIGHT***

ANSI, CSA	2,575 lbs	1,168 kg	2,702 lbs	1,226 kg
CE indoor	2,718 lbs	1,233 kg	3,302 lbs	1,498 kg
AUS indoor	—	—	3,302 lbs	1,498 kg

STANDARDS COMPLIANCE

ANSI A92.6, CSA B354.2, CE Compliance, AS 1418.10, PB-10-611-03

* The metric equivalent of working height adds 2 m to platform height. U.S. adds 6 ft to platform height.
 ** Gradeability applies to driving on slopes, see operator's manual for details regarding slope ratings.
 *** Weight will vary depending on options and/or country standards.

Features

STANDARD FEATURES

MEASUREMENTS

GS™-1530

- 21 ft (6.57 m) working height
- Up to 600 lb (272 kg) lift capacity

GS™-1930

- 25 ft (7.79 m) working height
- Up to 500 lb (227 kg) lift capacity

PRODUCTIVITY

- 64 x 29 in (1.63 x .74 m) steel platform
- Fixed rail with chain entry gate
- 36 in (.91 m) extension deck
- Dual front wheel drive
- Proportional lift and drive
- Automatic battery charger
- 30% gradeability
- Onboard diagnostic system
- AC power to platform
- Manual platform lowering valve
- Emergency stop at both platform and ground controls
- Multiple disc brakes
- Brake release
- Solid non-marking tires
- Pothole guards
- Tilt level sensor with audible alarm
- Descent alarm
- Electronic horn
- Hour meter

POWER

- 24 V DC (four 6 V 225 Ah batteries)

OPTIONS & ACCESSORIES

PRODUCTIVITY

- Folding rails with half-height swing gate
- Platform swing gate, half-height
- Air line to platform
- Dual flashing beacons
- Motion package
- Platform work lights
- Ground controls cover
- Automotive horn

POWER

- Power inverter
- Maintenance-free batteries
- EE rating

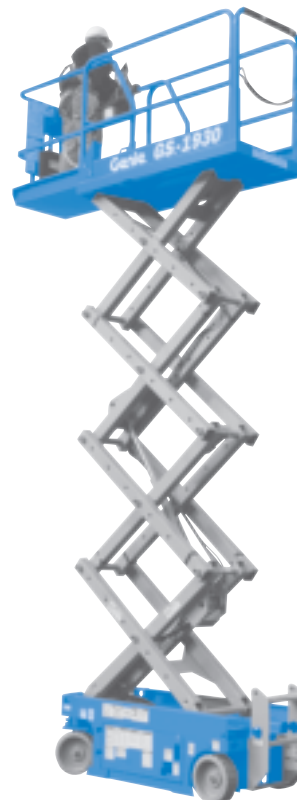

Genie United States

18340 NE 76th Street
P.O. Box 97030
Redmond, Washington 98073-9730

Telephone **(425) 881-1800**
Toll Free in USA/Canada **800-536-1800**
Fax (425) 883-3475

Genie Europe

The Maltings
Wharf Road
Grantham NG31 6BH
U.K.

Telephone **+44 (0)1476 584333**
Fax +44 (0)1476 584334

Email: infoeurope@genieind.com

Distributed By:

For further information, please contact your local distributor or the Genie Industries sales office listed. Product specifications are subject to change without notice or obligation. The photographs and drawings in this brochure are for illustrative purposes only. Refer to the appropriate Operator's Manual for instructions on the proper use of this equipment. Failure to follow the appropriate Operator's Manual when using our equipment or to otherwise act irresponsibly may result in serious injury or death. Prices and specifications subject to change without notice. The only warranty applicable is the standard written warranty applicable to the particular product and sale. Genie makes no other warranty, expressed or implied. Products and services listed may be trademarks, service marks or trade-names of TEREX Corporation and/or its subsidiaries in the USA and other countries and all rights are reserved. Copyright © 2006 Genie Industries, Inc. "Genie" is a Registered Trademark of Genie Industries, Inc. in the USA and many other countries. Genie is a TEREX Company.